

# andrew harris woodwork

## Chest of Drawers Plans



# andrew harris woodwork

## Introduction

This plan makes a chest of drawers from 2 by 4s and 2 by 6s for the top. The cabinet is 22 ½ inches at the widest point, 22 inches deep and 31 inches high.

All my builds are made with pocket hole joinery. You will need a pocket hole jig tool such as a Kreg Pocket Hole Jig in order to build them.

The 2 by 4 and 2 by 6 was actually taken from an old work bench and so the dimensions were dictated to some extent by the wood I had available from that and the cuts I could make from it.

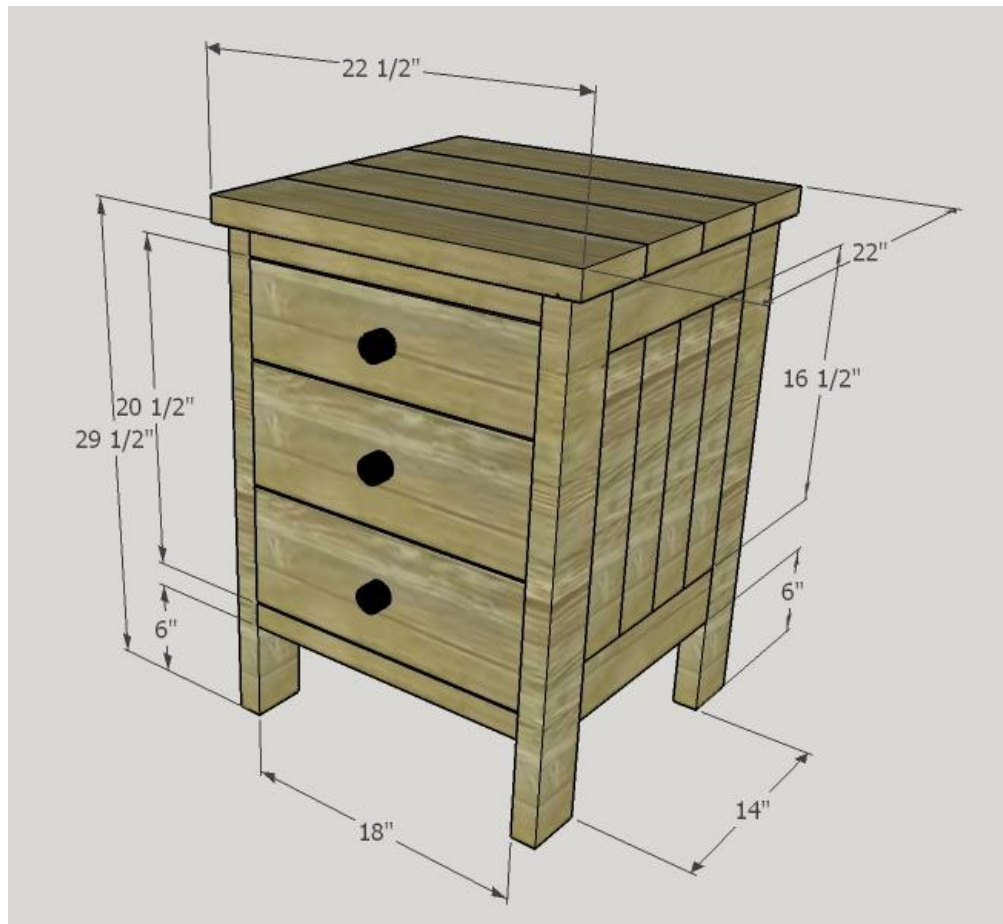

I have tried to ensure all steps are covered in these plans but if you find any errors in the plans or have a question then please email me at [info@andrewharriswoodwork.com](mailto:info@andrewharriswoodwork.com) to let me know.

# andrew harris woodwork

## Shopping List

Size	Length	Quantity	Board Number
2 by 4	8 feet	5	1 to 5
1 by 4	6 feet	1	6
1 by 6	6 feet	2	7
1 by 6	8 feet	1	8
2 by 6	8 feet	1	9
1 by 8	8 feet	1	10
Drawer slides	16 inch	3 pairs	
¼ inch plywood	See build notes as will depend on method of drawer construction		

You will also need:

- Pocket Hole Tool such as a Kreg Pocket Hole Jig
- 1.25 inch pocket screws
- 2.5 inch pocket screws
- 1.25 inch wood screws
- 2.5 inch wood screws
- ¾ inch finishing nails
- Wood glue
- Drawer pulls

**Estimated Material Cost:** This piece was made from recycled and scrap wood and so the only cost was for the hardware of around \$30 plus the cost of screws (around \$10).

If you were to buy the wood to make it then I worked out it would be around \$95 plus cost of desired drawer pulls.

# andrew harris woodwork

## Cut list

Please read all instructions before cutting wood as shown below. I suggest some pieces are cut as you go to ensure a tight fit.

To minimize the number of boards to use plan your cuts I have given details of which board you should cut the piece from. If you find a more economical solution then please let me know.

Size	Length (inches)	Quantity	Used For	Board Number
2 by 4	29 ½	4	Legs	1 and 2
2 by 4	16 ½	10	Side inserts and back vertical supports	3,4 and 2 from 5
2 by 4	14	4	Side rails	3 and 4
2 by 4	18	4	Front and back rails	1 and 2
1 by 4	16	2	Small drawer	6
1 by 4	15 ½	2	Small drawer	6
1 by 6	15 ½	4	Larger drawers	7
1 by 6	16	4	Larger drawers	8
1 by 6	17 ¾	1	Drawer Front	7
2 by 6	22 1/3	4	Top	9
1 by 8	17 ¾	2	Drawer Front	10
¼ inch ply			Cut for bottom of drawers depending on whether using inset bottoms or fixed to bottom.	
¼ inch ply	12 inches by 17 1/2 inches		For back panel (fitted from inside)	

# andrew harris woodwork

## Step 1 – Make the two Side panel inserts

I made the inserts for the sides from 4 four pieces of 2 by 4.

Put the pocket holes on the inside and also put a pocket hole in the top and bottom of each piece to fix to the top and bottom rails.

If you prefer you can use a piece of plywood for a solid panel look instead.

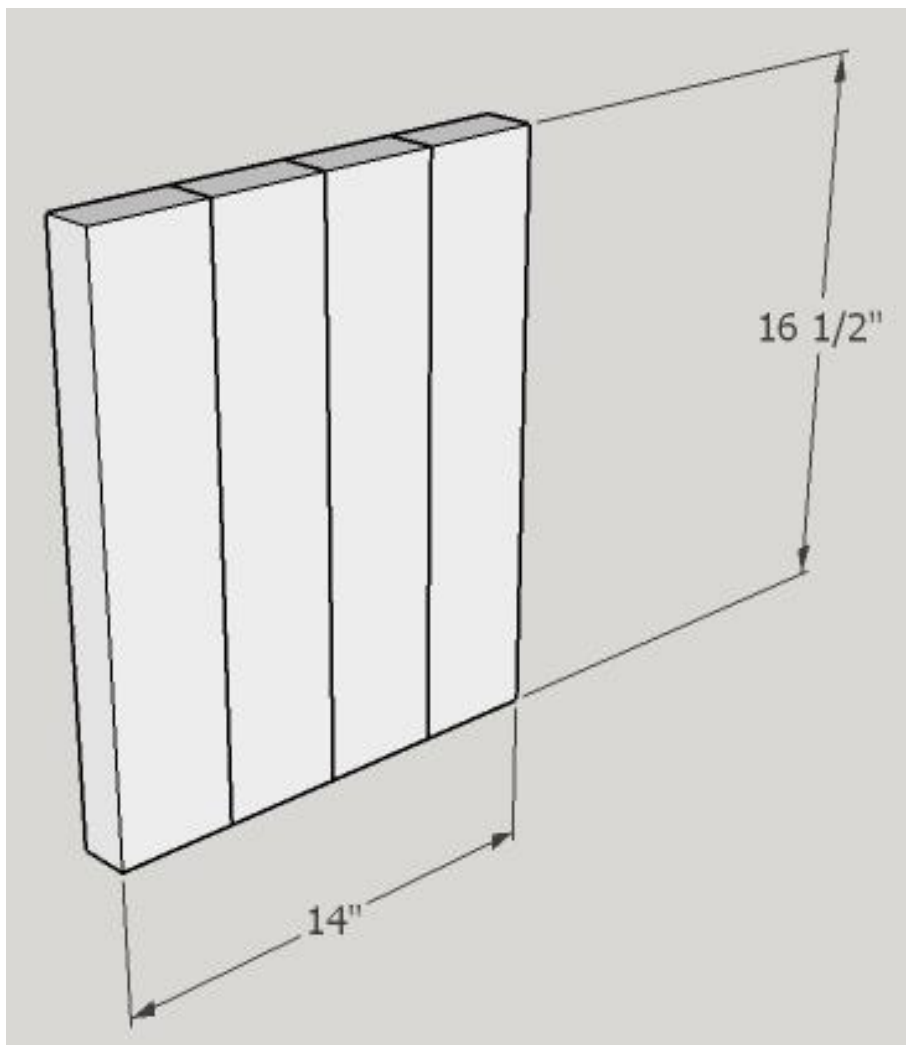

# andrew harris woodwork

## Step 2– Make the two Side frames

Make the side frame by attaching the two 29.5 inch legs and the 14 inch 2 by 4s as the top and bottom rails.

The actual width of the 2 by 4s may not be exactly 3.5 inches and so you may need to trim the 14 inch side rails slightly once you have the insert part made.

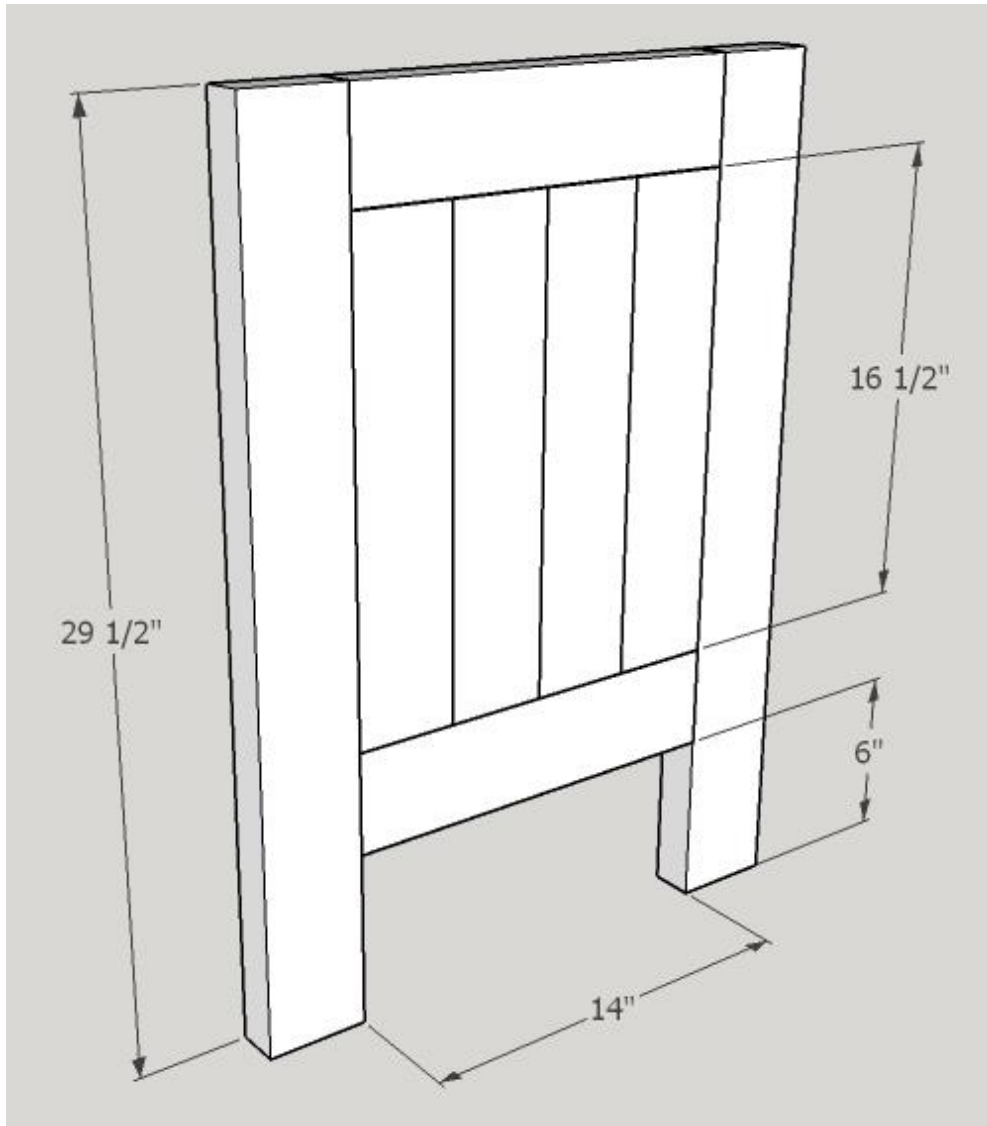

# andrew harris woodwork

## Step 3 – Add the back rails

Add the 2 by 4 pieces of back rail as shown.

Make sure the pocket holes are on the inside. The pocket holes should be drilled on the narrow part of each piece.

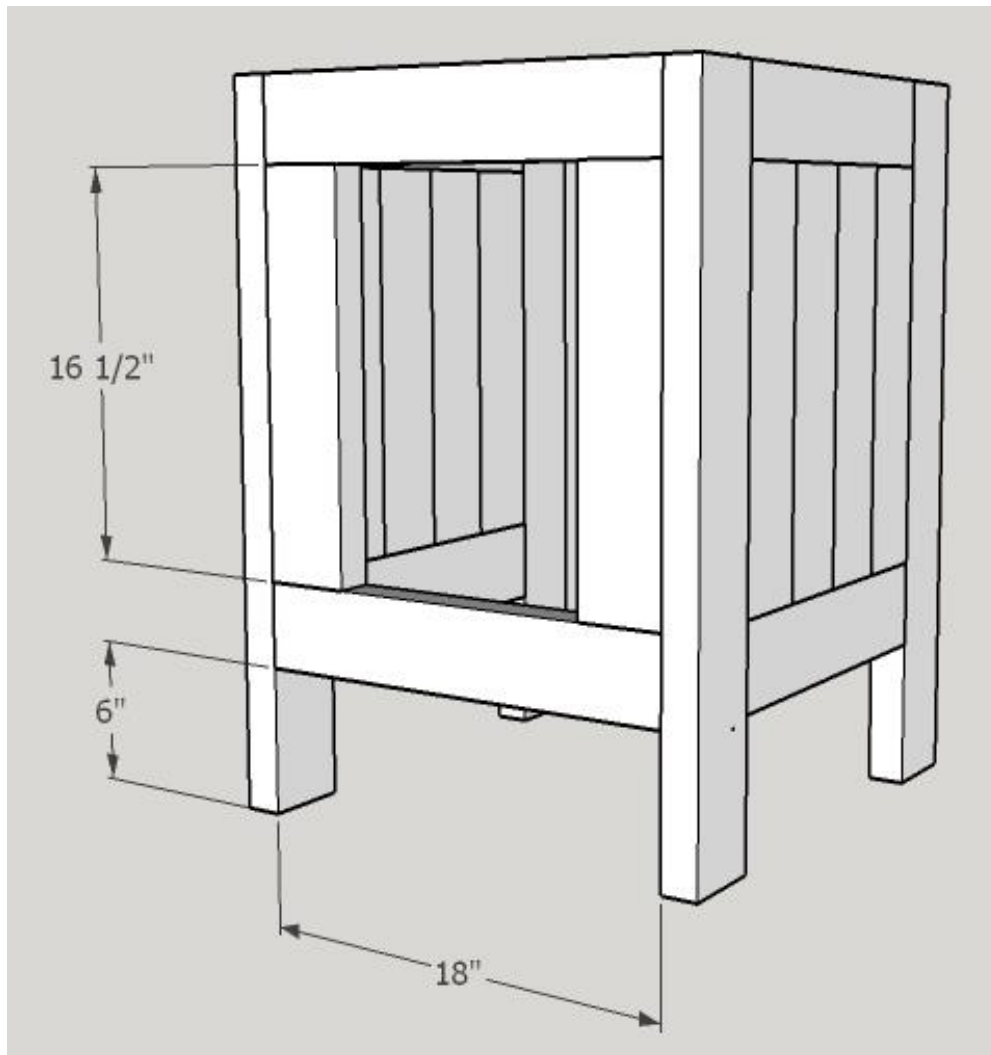

# andrew harris woodwork

## Step 4 – Add the front rails

Add the 2 by 4 front rail pieces as shown.

I put the pocket holes for the top rail on the top so would be hidden by the top. For the bottom rail I put them underneath so they would be hidden. The pocket holes should be drilled on the narrow end part of each piece.

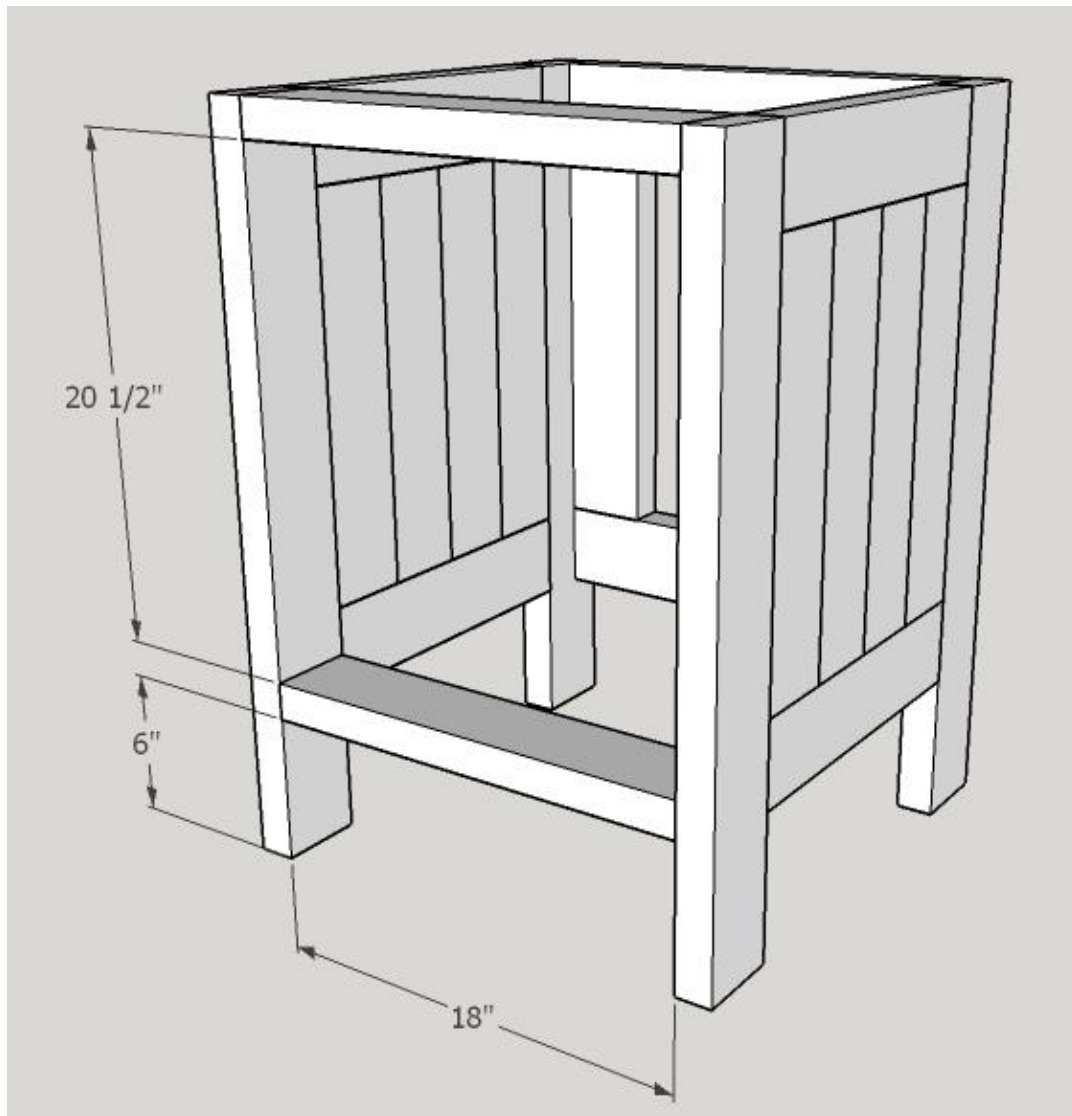



# andrew harris woodwork

## Step 5 – Make the Top Smaller Drawer

Drill pocket holes in the both ends of the 15 ½ inch length drawer pieces.

Join the 16 inch pieces to the 15 ½ inch lengths to form the drawers.

You can either route the sides to fit ¼ inch plywood base inside or fix the base to the bottom.

Fit the drawer slides to the bottom of the drawers as well.

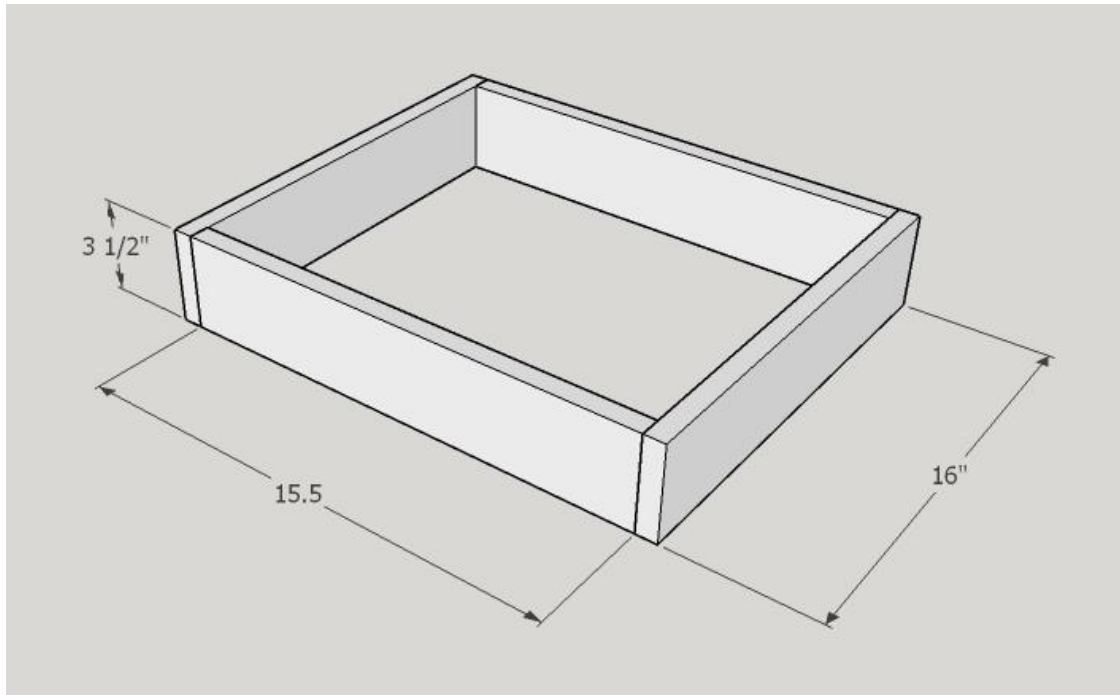

# andrew harris woodwork

## Step 6 – Make the two deeper drawers

Drill pocket holes in the both ends of the 15 ½ inch length drawer pieces.

Join the 16 inch pieces to the 15 ½ inch lengths to form the drawers.

You can either route the sides to fit ¼ inch plywood base inside or fix the base to the bottom.

Fit the drawer slides to the bottom of the drawers as well.

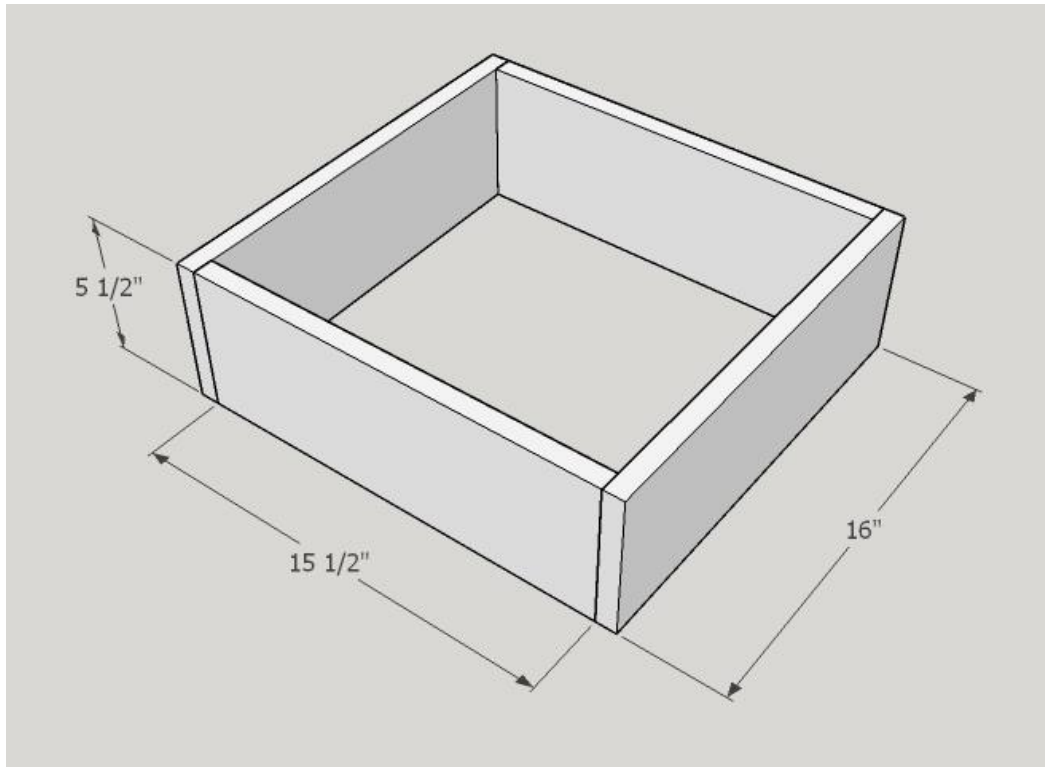

# andrew harris woodwork

## Step 7 – Fit the drawer slides to frame of cabinet

Follow the instructions of your slides to fit them to the sides of the cabinet. Usually there should end up being half an inch gap between the bottom of the drawers and top of the rail underneath it but follow the instructions that come with your drawer slides.

## Step 8– Fit the drawer fronts

The small drawer front is the 1 by 6 piece measuring  $17 \frac{3}{4}$  inches long (1/4 inch narrower than the space they are fitting). Measure and cut to fit your project though.

The large drawer fronts are the 1 by 8 pieces measuring  $17 \frac{3}{4}$  inches long (1/4 inch narrower than the space they are fitting). Measure and cut to fit your project though.

Fit the drawer fronts ensuring equal gap at top and outer edge for both.

Drill two holes through the inner drawer front and then fix the outer drawer front by screwing through the inner drawer front into the outer drawer front using  $1 \frac{1}{4}$  inch screws.

Tip - clamp the drawer front in position when happy with the spacing and then screw it in place.

## Step 9 – Make the top

Make the top from the four 2 by 6 pieces measuring 22.5 inches long (this gives a  $\frac{3}{4}$  inch overlap on each side).

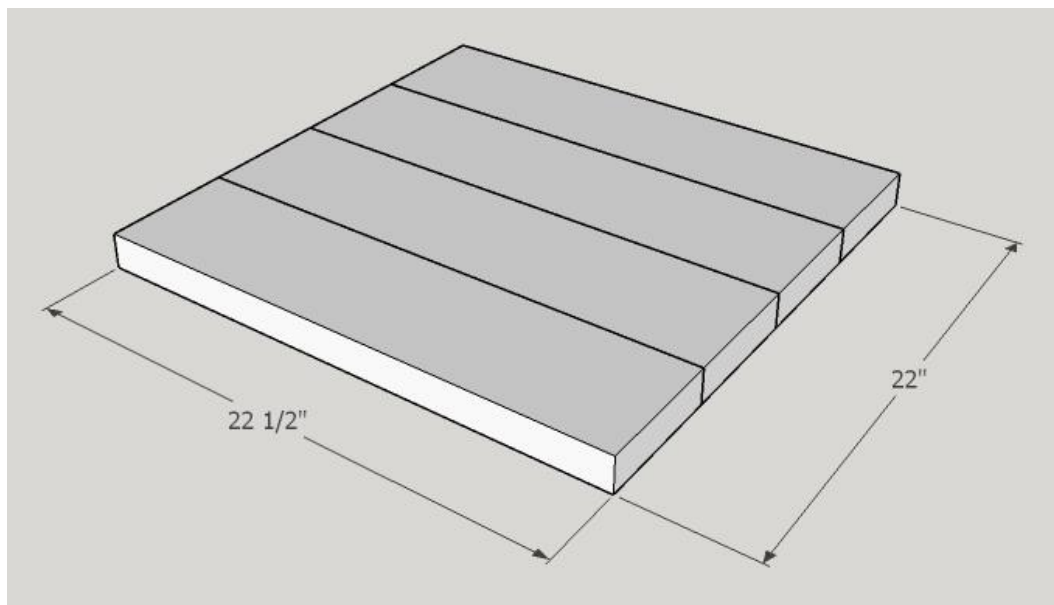

# andrew harris woodwork

## Step 10 – Fit the top

Drill pocket holes on the side and back panels facing upward for screwing the first top layer to with 2 ½ inch pocket hole screws.

Drill through the top of the front 2 by 4 rail so the top can be screwed on from underneath.

Place the top with the good side down and then place the upturned cabinet on top. Make sure you have equal gap all around and then fix the sides and back with 1 ¼ inch pocket hole screws and the front edge with 2.5 inch wood screws through the front rail.

## Step 11 – Fit the back panel

Fit the back panels from the inside. I suggest you leave at least half an inch gap around the edge and use ¾ inch finishing nails to fix it. Dimensions given in plan (12 inches by 17 ½ inches) allow for 1 inch overlap around each side.

## Step 12 – Finish

Sand well to smooth our joints and remove any wood glue residue.

Apply Pre stain and your choice of color or paint as desired. The example in these plans was finished in Varathane Carrington and Varathane Matte Poly.

## Step 13– Hardware

Add hardware of your choice to the drawers (you will need to temporarily remove the front drawer parts).